



AIRDRAIN FOR ARTIFICIAL TURF

SUBMITTAL PACKAGE FOR ARTIFICIAL TURF
DRAINAGE APPLICATIONS

SPRING 2025



AIRDRAIN ARTIFICIAL TURF APPLICATION DATA AND SPECIFICATIONS

AIRDRAIN GENERAL DATA	03
AIRDRAIN CROSS SECTION	04
AIRDRAIN SYNTHETIC TURF DETAIL	05
AIRDRAIN SYNTHETIC EDGE DETAIL	06
AIRDRAIN SYNTHETIC PERMEABLE SYSTEM	07
AIRDRAIN SYNTHETIC EDGE ON COMPACTED AGGREGATE BASE	08
AIRDRAIN SYNTHETIC EDGE ON ROOF TOP	09
AIRDRAIN SYNTHETIC WITH PAD APPLICATIONS	10
AIRDRAIN SYNTHETIC EDGE ON PET AREAS	11
AIRDRAIN MSDS AND GENERAL SPECIFICATIONS	12
AIRDRAIN SAFETY TESTING	13
PROPER SEQUENCING AND INSTALLATION	18
STATEMENT OF 100% POST RECYCLED CONTENT	20

AIRDRAIN

BY AIRFIELD SYSTEMS

An advanced geocell solution for modern artificial turf construction. AirDrain provides rapid water drainage, collection, retention, and reuse for sports fields, K9 areas, playgrounds, rooftops and more.. It is the most efficient, water saving drainage design and is made of 100% recycled content, making it a practical part of true green building.

AN AIRDRAIN SYSTEM PROVIDES CONSISTENT DRAINAGE ACROSS ANY SURFACE

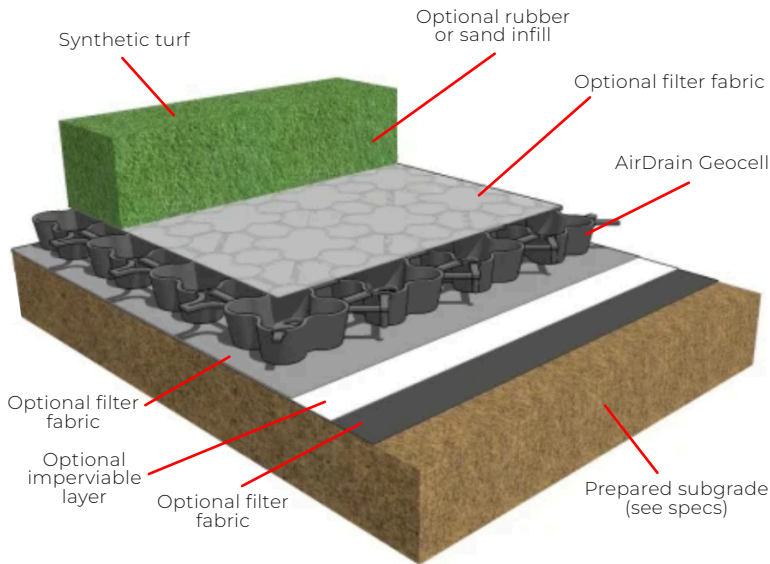

AirDrain's performance is unmatched in the artificial turf drainage industry. The consistent Gmax and shock attenuation properties of an AirDrain system contribute to the safety of players, with an up 90% reduction in concussions and impact injuries.

Unlike traditional shock pads or e-layers, AirDrain is 1" high with a 92% air void and 100% vertical drainage. It can be used on any type of prepared sub base, including compacted aggregate, concrete, asphalt, and rooftops.

BENEFITS OF AN AIRDRAIN ARTIFICIAL TURF SYSTEM INCLUDE:

- Helps maintain a constant Gmax for the life of the project.
- ASTM proven shock absorption for reduced Gmax.
- Requires only a .25% slope for effective drainage.
- No buckling with a patented expansion and contraction feature.
- Only limited by the drainage capacities of the profile above and the exit drains below.
- Can be reused multiple times when the synthetic turf is replaced.
- Can add to LEED points.
- Less expensive to ship than most systems.

GRID SPECIFICATIONS

The AirPaver design is simple, less expensive to ship, and quick to install. Each part is 32" x 32" x 1", weighs 3.10 lbs, and is 8% solid.

SHIPPING SPECIFICATIONS

Each 390 lb. Pallet contains 114 parts, or 798 sq. ft. A trailer holds 114 pallets, or 90,972 sq. ff. and is loaded 3 wide x 2 tall x 19 deep.

*This drawing, specifications and the information contained herein is for general presentation purposes only. All final drawings and layouts should be determined by a licensed engineer(s).



AIRFIELD SYSTEMS, LLC
8028 N. MAY AVE, STE 201
OKLAHOMA CITY, OK 73120
PHONE: (405) 359-3775
FAX: (405) 348-9945
www.airfieldsystems.com

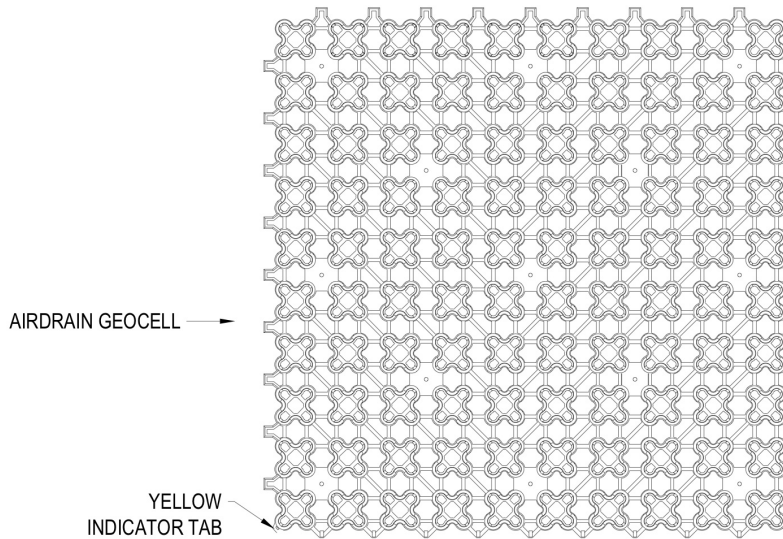

PLAN



SECTION

SPECIFICATIONS

SIZE: 32" X 32" X 1"

WEIGHT: 3.1 LB

STRENGTH: 233 PSI (UNFILLED) 6747 PSI (FILLED)

RESIN: 100% RECYCLED (PIR) COPOLYMER WITH IMPACT MODIFIER "NO BREAK" POLYMER

MATERIAL COLOR: BLACK (3% CARBON BLACK ADDED FOR UV PROTECTION)

MANUFACTURER NOTES:

DRAINS APPROXIMATELY 50 GALLONS PER MINUTE PER SQUARE FOOT. NEEDS MINIMAL SLOPE OF .50% TO ACHIEVE DRAINAGE

HOLDS .576 GALLONS WATER PER SQUARE FOOT

NOTES:

1. INSTALLATION TO BE COMPLETED IN ACCORDANCE WITH MANUFACTURER'S SPECIFICATIONS.
2. DO NOT SCALE DRAWING.
3. THIS DRAWING IS INTENDED FOR USE BY ARCHITECTS, ENGINEERS, CONTRACTORS, CONSULTANTS AND DESIGN PROFESSIONALS FOR PLANNING PURPOSES ONLY. THIS DRAWING MAY NOT BE USED FOR CONSTRUCTION.
4. ALL INFORMATION CONTAINED HEREIN WAS CURRENT AT THE TIME OF DEVELOPMENT BUT MUST BE REVIEWED AND APPROVED BY THE PRODUCT MANUFACTURER TO BE CONSIDERED ACCURATE.
5. CONTRACTOR'S NOTE: FOR PRODUCT AND COMPANY INFORMATION VISIT www.CADdetails.com/info AND ENTER REFERENCE NUMBER 975-030b.



975-030b

REVISION DATE 07/03/2023

PROTECTED BY COPYRIGHT ©2023 CADDETAILS.COM LTD.

CADdetails.com



AIRFIELD SYSTEMS, LLC
 8028 N. MAY AVE, STE 201
 OKLAHOMA CITY, OK 73120
 PHONE: (405) 359-3775
 FAX: (405) 348-9945
 www.airfieldsystems.com

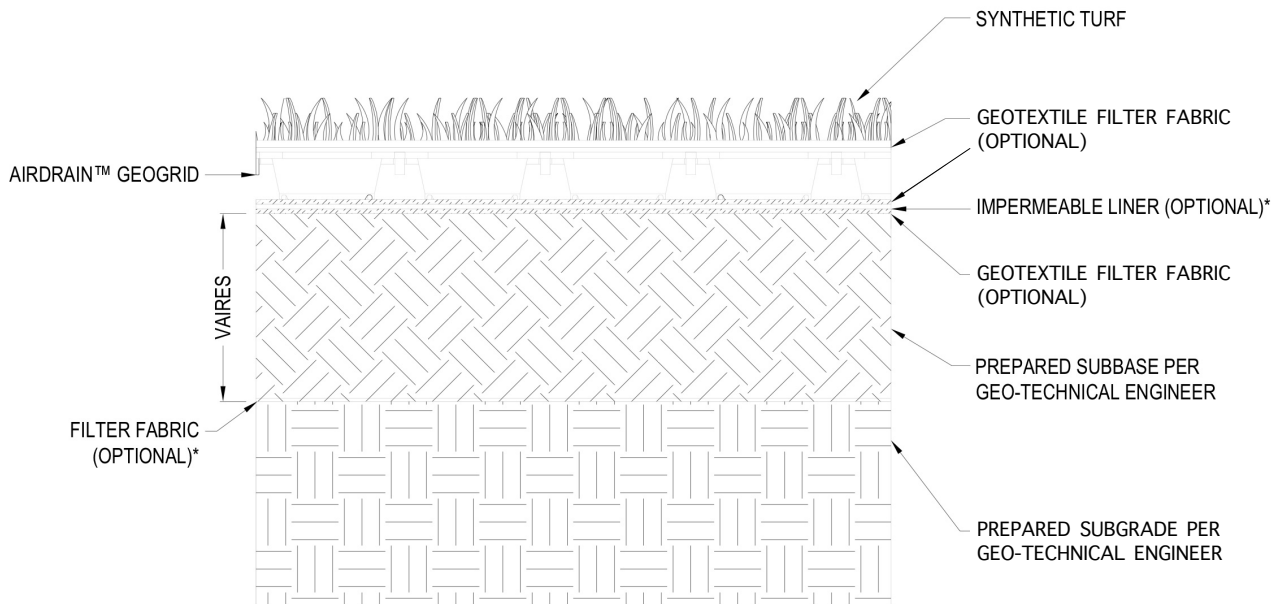

SECTION

NOTES:

1. INSTALLATION TO BE COMPLETED IN ACCORDANCE WITH MANUFACTURER'S SPECIFICATIONS.
2. DO NOT SCALE DRAWING.
3. THIS DRAWING IS INTENDED FOR USE BY ARCHITECTS, ENGINEERS, CONTRACTORS, CONSULTANTS AND DESIGN PROFESSIONALS FOR PLANNING PURPOSES ONLY. THIS DRAWING MAY NOT BE USED FOR CONSTRUCTION.
4. ALL INFORMATION CONTAINED HEREIN WAS CURRENT AT THE TIME OF DEVELOPMENT BUT MUST BE REVIEWED AND APPROVED BY THE PRODUCT MANUFACTURER TO BE CONSIDERED ACCURATE.
5. CONTRACTOR'S NOTE: FOR PRODUCT AND COMPANY INFORMATION VISIT www.CADdetails.com/info AND ENTER REFERENCE NUMBER 975-040b.

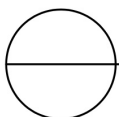

SPORTS FIELDS – SYNTHETIC TURF DRAINAGE

SYNTHETIC TURF DRAINAGE DETAIL

975-040b

REVISION DATE 07/03/2023

PROTECTED BY COPYRIGHT ©2023 CADDETAILS.COM LTD.

CADdetails.com



AIRFIELD SYSTEMS, LLC
 8028 N. MAY AVE, STE 201
 OKLAHOMA CITY, OK 73120
 PHONE: (405) 359-3775
 FAX: (405) 348-9945
 www.airfieldsystems.com

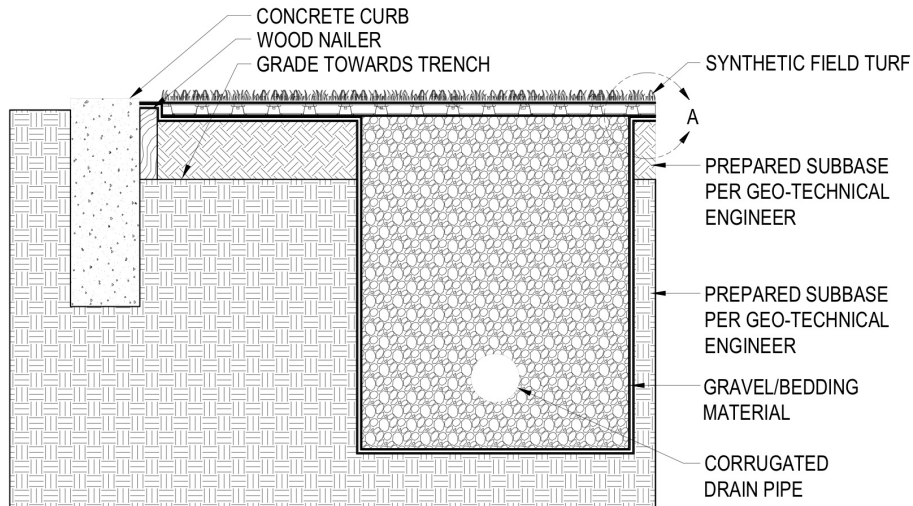

SECTION

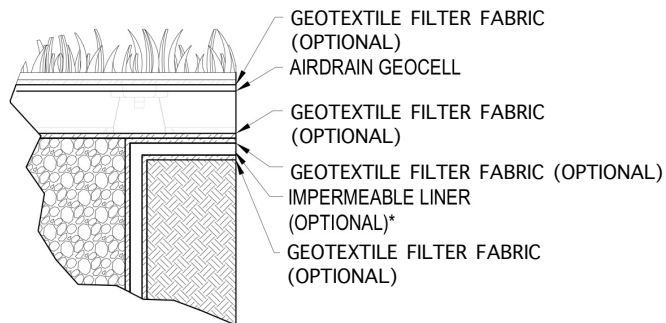

DETAIL A

NOTES:

1. INSTALLATION TO BE COMPLETED IN ACCORDANCE WITH MANUFACTURER'S SPECIFICATIONS.
2. DO NOT SCALE DRAWING.
3. THIS DRAWING IS INTENDED FOR USE BY ARCHITECTS, ENGINEERS, CONTRACTORS, CONSULTANTS AND DESIGN PROFESSIONALS FOR PLANNING PURPOSES ONLY. THIS DRAWING MAY NOT BE USED FOR CONSTRUCTION.
4. ALL INFORMATION CONTAINED HEREIN WAS CURRENT AT THE TIME OF DEVELOPMENT BUT MUST BE REVIEWED AND APPROVED BY THE PRODUCT MANUFACTURER TO BE CONSIDERED ACCURATE.
5. CONTRACTOR'S NOTE: FOR PRODUCT AND COMPANY INFORMATION VISIT www.CADdetails.com/info AND ENTER REFERENCE NUMBER 975-041b.

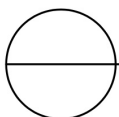

SPORTS FIELDS – SYNTHETIC TURF DRAINAGE

SYNTHETIC TURF DRAINAGE FIELD EDGE DETAIL



AIRFIELD SYSTEMS, LLC
 8028 N. MAY AVE, STE 201
 OKLAHOMA CITY, OK 73120
 PHONE: (405) 359-3775
 FAX: (405) 348-9945
 www.airfieldsystems.com

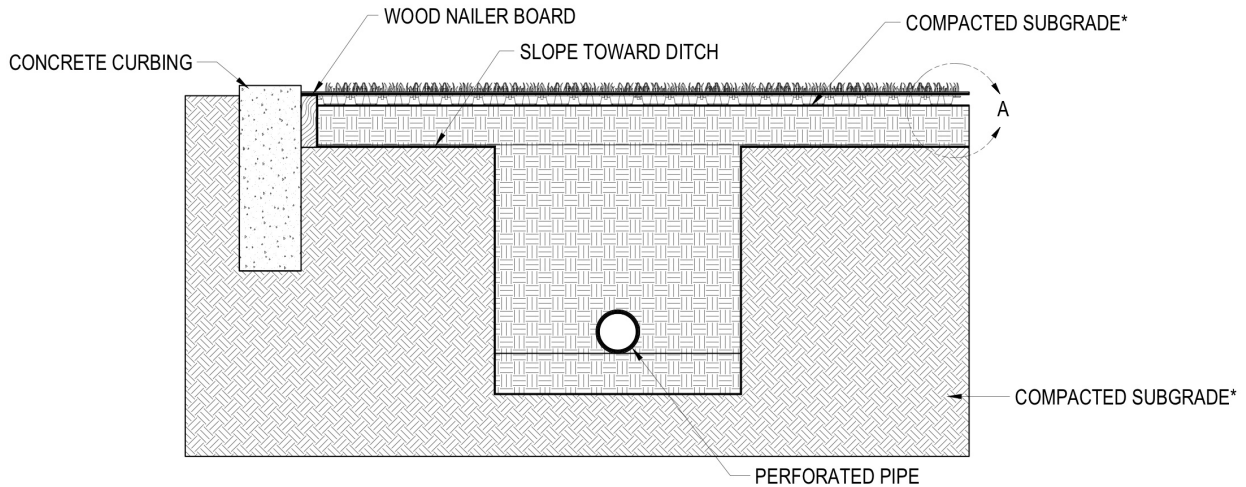

SECTION

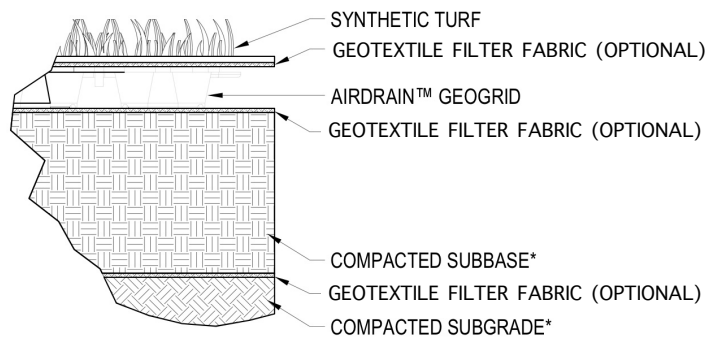

DETAIL A

*SPECIFICATIONS AS PER GEO-TECHNICAL ENGINEER.

NOTES:

1. INSTALLATION TO BE COMPLETED IN ACCORDANCE WITH MANUFACTURER'S SPECIFICATIONS.
2. DO NOT SCALE DRAWING.
3. THIS DRAWING IS INTENDED FOR USE BY ARCHITECTS, ENGINEERS, CONTRACTORS, CONSULTANTS AND DESIGN PROFESSIONALS FOR PLANNING PURPOSES ONLY. THIS DRAWING MAY NOT BE USED FOR CONSTRUCTION.
4. ALL INFORMATION CONTAINED HEREIN WAS CURRENT AT THE TIME OF DEVELOPMENT BUT MUST BE REVIEWED AND APPROVED BY THE PRODUCT MANUFACTURER TO BE CONSIDERED ACCURATE.
5. CONTRACTOR'S NOTE: FOR PRODUCT AND COMPANY INFORMATION VISIT www.CADdetails.com/info AND ENTER REFERENCE NUMBER 975-079.

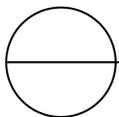

SPORTS FIELDS – SYNTHETIC TURF DRAINAGE

SYNTHETIC TURF PERMEABLE SYSTEM

Synthetic Turf Detail

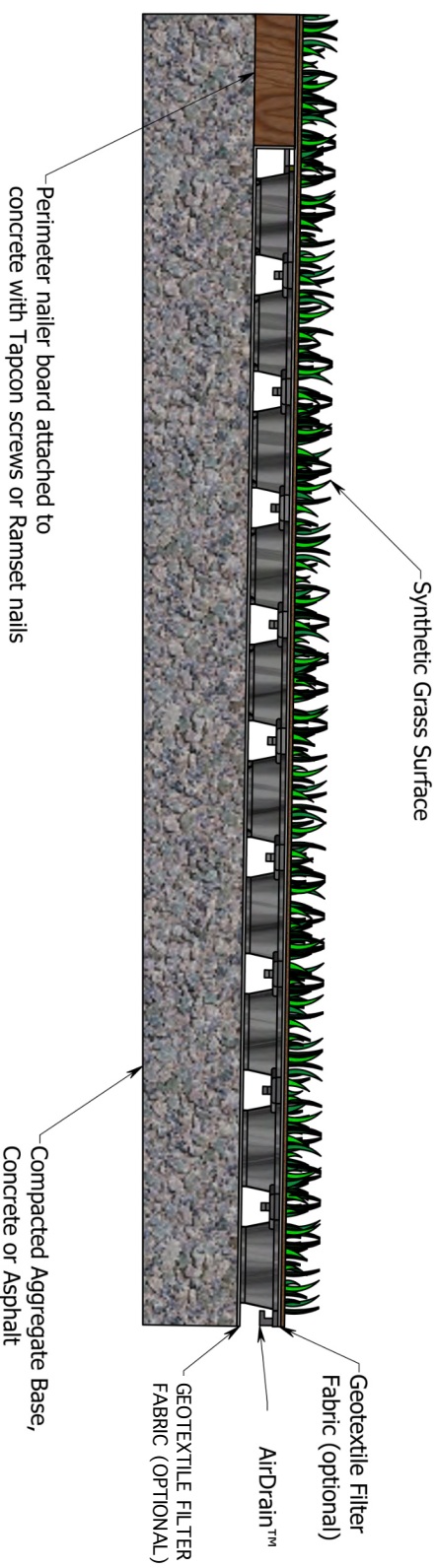

AirDrain™ Unit Panel Specifications:

- Size: 32" x 32" x 1"
- Weight: 3.1 lb
- Strength: 233 psi (unfilled)
- Resin: 100% Recycled (PIR) Copolymer with Impact Modifier
- "No Break" Polymer Material
- Color: Black (3% carbon black added for UV Protection)

Airfield Systems
 8028 N. May Ave., Suite 201
 Oklahoma City, OK 73120
 (405) 359-3775
www.airfieldsystems.com

This drawing, specifications and the information contained herein is for general presentation purposes only. All final drawings and layouts should be determined by a licensed engineer(s).



DATE	1/13/2013	TITLE	
DRAWN	Gary	Airfield Systems	
CHECKED		Synthetic Turf Edge Detail	
QA		on Compacted Aggregate Base	
MFG		SIZE	REV
APPROVED		C	1
The information contained in this drawing is the sole property of Airfield Systems. Any reproduction in whole or in part without prior written consent is prohibited.		SCALE	
		Concrete SP REV. 001	
		SHEET 1 OF 1	

Synthetic Turf Rooftop

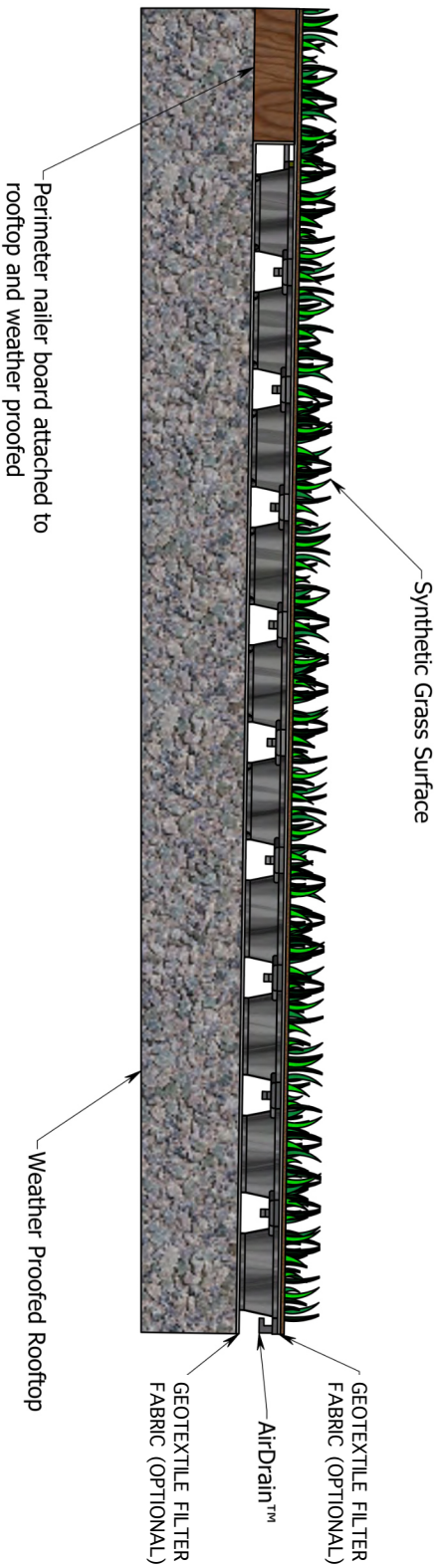

Now Available "Air-Drain FR" E-108 Class A Rated ZERO SPREAD OF FLAME

- Air-Drain™ Unit Panel Specifications:**
- Size: 32" x 32" x 1"
 - Weight: 3.1 lb
 - Strength: 233 psi (unfilled)
 - Resin: 6747 psi (filled)
 - 100% Recycled (PIR)
 - Copolymer with Impact Modifier
 - "No Break" Polymer Material
 - Black
 - (3% carbon black added for UV Protection)

Airfield Systems
 8028 N. May Ave., Suite 201
 Oklahoma City, OK 73120
 (405) 359-3775
www.airfieldsystems.com

This drawing, specifications and the information contained herein is for general presentation purposes only. All final drawings and layouts should be determined by a licensed engineer(s).



DRAWN	Gary	1/13/2013	TITLE		Airfield Systems
CHECKED			Synthetic turf Edge Detail		
QA			on Roof Top		
WFG			SIZE	DWG NO	REV
APPROVED			C	Concrete SP REV. 001	1
<small>The information contained in this drawing is the sole property of Airfield Systems. Any reproduction in whole or in part without prior written consent is prohibited.</small>			SCALE	SHEET 1 OF 1	

AirDrain Application with Pad Below AirDrain

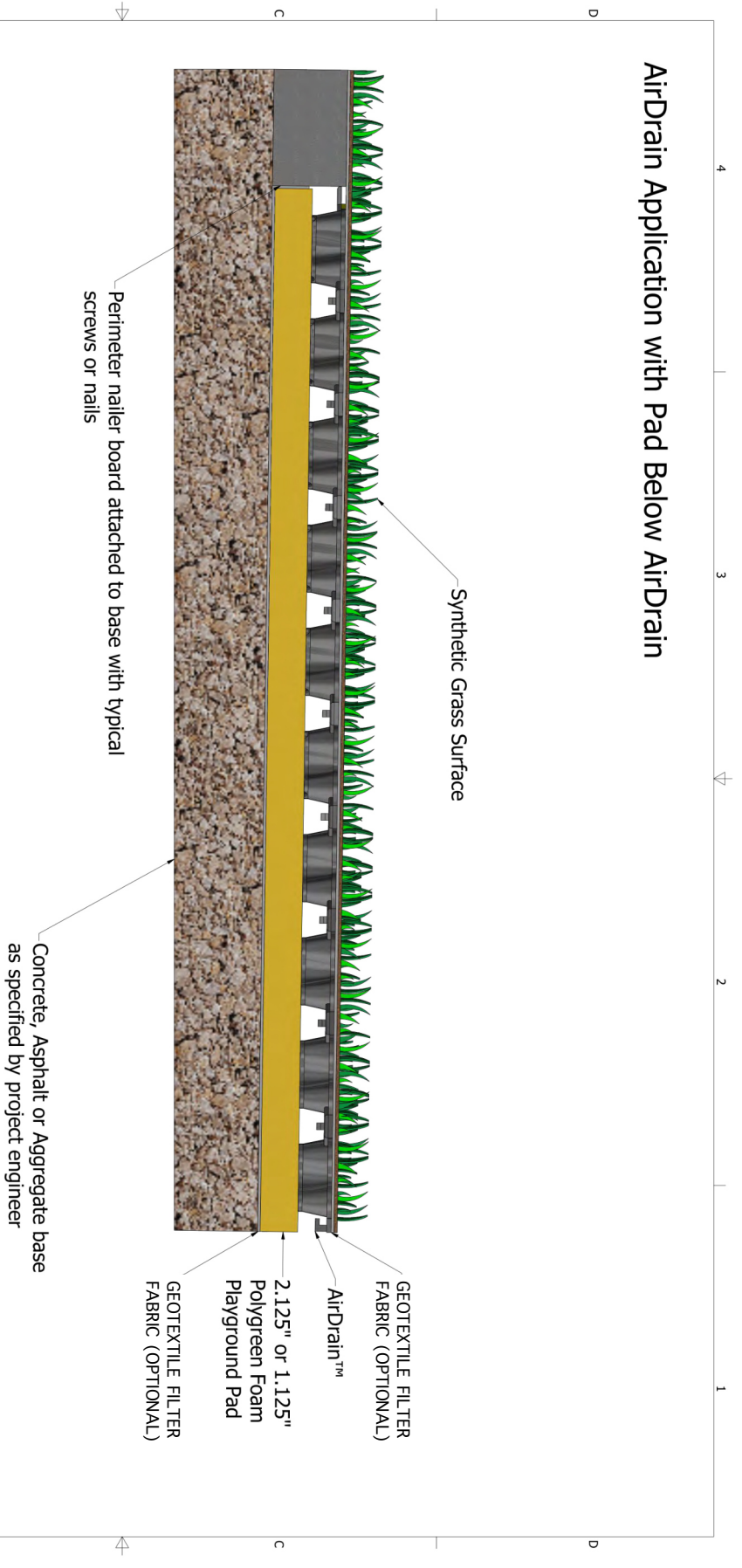

AirDrain™ Unit Panel Specifications:

- Size: 32" x 32" x 1"
- Weight: 3.1 lb
- Volume: 8% material, 92% air void
- Strength: 233 psi (unfilled)
- Resin: 100% Recycled (PIR)
Copolymer with Impact Modifier
"No Break" Polymer Material
- Color: Black (3% carbon black added for UV Protection)

This drawing, specifications and the information contained herein is for general presentation purposes only. All final drawings, specifications and layouts should be determined by a licensed engineer(s). Not to Scale



DRAWN	G. Abdo	2/22/2015	TITLE	AirField Systems	
CHECKED			AirDrain Application with Pad Below AirDrain		
QA			SIZE	DWG NO	REV
MFG			C	Playground_AFS_SP_Under	REV_001
APPROVED			SCALE	SHEET 1 OF 1	

Pet Areas and Dog Runs

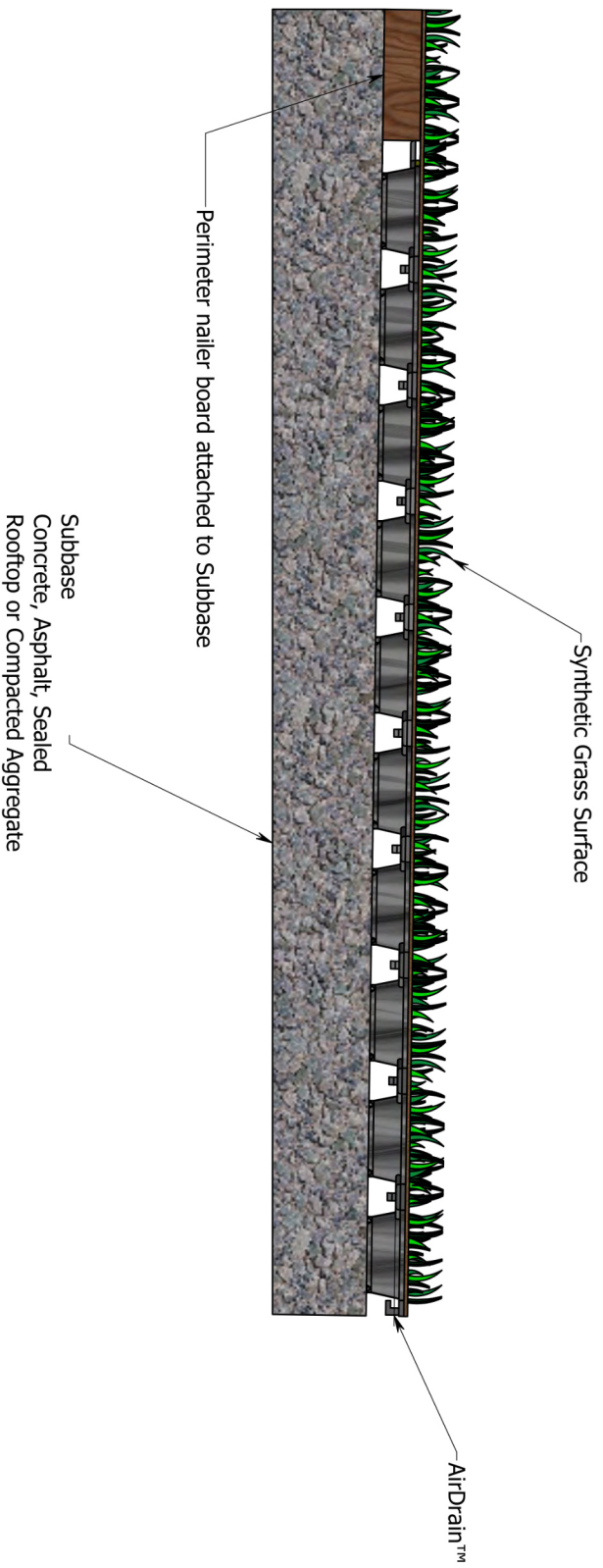

AirDrain™ Unit Panel Specifications:

- Size: 32" x 32" x 1"
- Weight: 3.1 lb
- Strength: 233 psi (unfilled)
- Resin: 100% Recycled (PIR) Copolymer with Impact Modifier "No Break" Polymer Material
- Color: Black (3% carbon black added for UV Protection)

This drawing, specifications and the information contained herein is for general presentation purposes only. All final drawings and layouts should be determined by a licensed engineer(s).



DRAWN Gary	8/6/2012	TITLE Airfield Systems	
CHECKED		Edge Detail on Pet Areas	
QA		SIZE C	REV
MFG		DWG NO Concrete Airpave_002	
APPROVED		SCALE	
The information contained in this drawing is the sole property of Airfield Systems. Any reproduction in whole or in part without prior written consent is prohibited.			
2		1	SHEET 1 OF 1

AIRDRAIN SPECIFICATIONS

The corresponding match the cross section.

General Information			
General			
Construction		Injection Molded Copolymer	
Composition		Copolymer Polypropylene Using Impact Modifier	
Dimensions		31.784" x 31.880" x 1.000" (7.03 sq ft.)	
Unit Weight		3.100 lbs.	
Forms		Pellets	
Shipping			
Parts Per Pallet		114	
Pallet Dimensions		33" x 33" x 48"	
Pallet Weight		390 lbs.	
Area Per Pallet		798 sq.ft.	
Pallets Per Trailer		114 (3 wide x 2 tall x 19 deep)	
Area Per Trailer		90,972 sq.ft.	
ASTM and ISO Properties ¹			
Physical		Nominal Value	Test Method
Specific Gravity		0.940	ASTM D792
Melt Mass-Flow Rate (230°C/ 2.16 kg)		20 g/ 10 min	ASTM D1238
Mechanical		Nominal Value	Test Method
Density		57.490 lb/ft ³	ASTM D1505
Tensile Strength (Yield, 73°F)		2,145 psi	ASTM D638
Tensile Elongation (Yield, 73°F)		16%	ASTM D638
Flexural Modulus (73°F)		100,175 psi	ASTM D790
Compression Strength (73°F)		233 psi (unfilled) 6,747 psi (sand filled)	ASTM D6254
Impact		Nominal Value	Test Method
Notched Izod Impact (73°F, 0.125 in)		-	ASTM D256
Thermal		Nominal Value	Test Method
Deflection Temperature Under Load 264 psi, Unannealed		160°F	ASTM D648
Expansion/Contraction Index ¹			
Temperature	Humidity	Length	Width
100°F	98%	31.881"	31.817"
-5°F	0%	31.765"	31.713"
Change		.116"	.104"
Joint Expansion/Contraction Capacity		.420"	.572"
Safety Factor		362%	550%
Examples of Usage			
Application		Required Strength	Safety Factor
Auto		40 psi	x 168
Truck		110 psi	x 61
DC10		250 psi	x 27
Space Shuttle		340 psi	x 19

¹Independent laboratory testing conducted by TRI/Environmental, Inc. - TSI/Testing Services, Inc. and Wassenaar.

SAFETY TESTING

Synthetic turf athletic fields built using an AirDrain system consistently outperform fields built over stone, concrete or asphalt, by reducing the Gmax and shock attenuation an average of 18.9% and 14.7% respectively, and helps maintain it for the life of the field.

This is confirmed through multiple tests conducted by TSI Testing Services (an approved independent Test Laboratory by the Synthetic Turf Council) using ASTM F355-10a: Standard Test Methods for Shock-Absorbing Properties of Playing Surface Systems and Materials.

Gravel Sub base: with the use of filter fabrics and AirDrain with infilled synthetic turf created a reduction in Gmax attenuation by 18.9% versus Gmax attenuation which employed just the turf and infill system using the same sub base.

Concrete Subbase: with the use of filter fabrics and AirDrain with infilled synthetic turf created a reduction in Gmax attenuation by 14.7 % versus Gmax attenuation which employed just the turf and infill system using the same sub base.

Player Safety

The consistent Gmax and shock attenuation properties of AirDrain are a major contributor to the reduction of concussions and the safety of your players. Some factors that might influence a change in GMAX would be an inconsistency of the infill or wear of the synthetic turf fibers. Unlike traditional shock pads or e-layers the AirDrain is 1" high, has a 92% air void and a vertical and lateral drainage rate which cannot be matched by any other product in the industry.

See testing results conducted by TSI Testing Services below.

Test Report

CLIENT:	AirField Systems	REPORT NUMBER:	56765
	8028 N. May Avenue Suite 201	LAB TEST NUMBER:	2497-5010
	Oklahoma City, OK 73120	DATE:	November 30, 2012
		PAGE:	1 of 2

Synthetic Turf Description: 46 oz/yd² Monofilament/Slit Film Fiber
 2.25" Pile Height Monofilament / 2.125" Pile Height Slit Film
 9.25 oz/yd² 3 Layer Primary Backing
 25.1 oz/yd² Secondary Urethane Backing

Infill System Installed: 3.0 lbs/ft² SBR Rubber Mixed with 1.25 lbs/ft² Silica Sand

Underlayment #1: 10 oz Filter Fabric (Between Sub Base and Drain System)

Drain System: Air Drain (Cups Down Against 10 oz Filter Fabric)

Underlayment #2: 4 oz Filter Fabric (On top of Flat Surface Air Drain, Under Turf)

Sub Base: 2" Layer # 7 & # 81 Rock
 1" Compacted Fines Layer

Discussion: Testing Services Inc was instructed to carry out testing on the sample supplied according to the following testing:

- Comparative Gmax or cushioning properties between the turf and sub base system vs. the turf + Air Drain + Filter Fabrics and sub base.

Material Received: 27 November 2012

Note: The above turf was selected from stock and its construction and infill properties are indicative a "typical" playing field for sports activity.

Approved By:

Erle Miles, Jr V.P., Testing Services Inc

TSi Accreditation: Our laboratory is accredited with US Dept of Commerce, National Institute of Standards and Technology: ISO/IEC 17025:2005. Our code # is NVLAP 100108-0. TSi is also recognized as an approved Independent Test Laboratory by the Synthetic Turf Council. However, it should be noted that some or all of the tests performed are not under our scope of accreditation due to the work not fully conforming to the standard, or it being outside the scope of our accreditation, or subcontracted.

Uncertainty: We undertake all assignments for our clients on a best effort basis. Our findings and judgments are based on the information to us using the latest test methods available.

Testing Atmosphere: Unless otherwise noted, all testing was conducted under standard lab conditions of 20± 2°C and 65 ± 4% r.h.

Report Date: 30 November 2012
 Report #: 56765
 Page #: 2 of 2

Client: AirField Systems

Date of Test: 29 November 2012

Test Conditions: 61.5°F 36% RH.

Procedure: **ASTM F355-10a: Standard Test Methods for Shock-Absorbing Properties of Playing Surface Systems and Materials (Procedure A)**

Data obtained from this test method are indicative of cushioning properties of the playing surface system and materials under the specific conditions selected. The playing system is impacted at a specified velocity with a missile of given mass and geometry to determine the maximum value of *G* encountered during impact.

The test set-up was positioned over the sub base with the clearview bumper II (gmax test equipment) placed level over the entire system. The missile was released, so as to impact the center of the assembly at a velocity of 3.43 m/s at a drop height of 24". Three drops were made at 3 minute intervals. The procedure was repeated in three different locations for a total of nine drops. The first drop at each location was for assembly conditioning and was not included in the average.

Test Data: Turf + Infill System Over Sub Base			
Location	G-Max Read Drop #2	G-Max Reading Drop #3	Average G-Max Reading
1	93	95	94
2	96	101	99
3	89	92	91
OVERALL GMAX:			95

Test Data: Turf + Infill System + 4 oz Filter Fabric + AirDrain + 10 oz Filter Fabric Over Sub Base ↓			
Location	G-Max Read Drop #2	G-Max Reading Drop #3	Average G-Max Reading
1	74	77	76
2	76	79	78
3	76	79	78
OVERALL GMAX:			77

Conclusion: Use of the filter fabrics and AirDrain with infilled synthetic turf reduced Gmax attenuation 18.9% verses Gmax attenuation which employed just the turf + infill system using the same sub base.

Test Report

CLIENT:	AirField Systems	REPORT NUMBER:	56765A
	8028 N. May Avenue Suite 201	LAB TEST NUMBER:	2497-5010
	Oklahoma City, OK 73120	DATE:	December 7, 2012
		PAGE:	1 of 2

Synthetic Turf Description: 46 oz/yd² Monofilament/Slit Film Fiber
 2.25" Pile Height Monofilament / 2.125" Pile Height Slit Film
 9.25 oz/yd² 3 Layer Primary Backing
 25.1 oz/yd² Secondary Urethane Backing

Infill System Installed: 3.0 lbs/ft² SBR Rubber Mixed with 1.25 lbs/ft² Silica Sand

Underlayment #1: 10 oz Filter Fabric (Between Sub Base and Drain System)

Drain System: Air Drain (Large Opening Up (Per Supplied Specs) Against 10 oz Filter Fabric)

Underlayment #2: 4 oz Filter Fabric (On top of Flat Surface Air Drain, Under Turf)

Sub Base:	Concrete
------------------	----------

Discussion: Testing Services Inc was instructed to carry out testing on the sample supplied according to the following testing:

- Comparative Gmax or cushioning properties between the turf and sub base system vs. the turf + Air Drain + Filter Fabrics and sub base.

Material Received: 27 November 2012

Note: The above turf was selected from stock and its construction and infill properties are indicative a "typical" playing field for sports activity.

Approved By:

Erle Miles, Jr V.P., Testing Services Inc

TSi Accreditation: Our laboratory is accredited with US Dept of Commerce, National Institute of Standards and Technology: ISO/IEC 17025:2005. Our code # is NVLAP 100108-0. TSi is also recognized as an approved Independent Test Laboratory by the Synthetic Turf Council. However, it should be noted that some or all of the tests performed are not under our scope of accreditation due to the work not fully conforming to the standard, or it being outside the scope of our accreditation, or subcontracted.

Uncertainty: We undertake all assignments for our clients on a best effort basis. Our findings and judgments are based on the information to us using the latest test methods available.

Testing Atmosphere: Unless otherwise noted, all testing was conducted under standard lab conditions of 20± 2°C and 65 ± 4% r.h.

Report Date: 7 December 2012
 Report #: 56765A
 Page #: 2 of 2

Client: AirField Systems

Date of Test: 7 December 2012

Test Conditions: 68°F 42% RH.

Procedure: **ASTM F355-10a: Standard Test Methods for Shock-Absorbing Properties of Playing Surface Systems and Materials (Procedure A)**

Data obtained from this test method are indicative of cushioning properties of the playing surface system and materials under the specific conditions selected. The playing system is impacted at a specified velocity with a missile of given mass and geometry to determine the maximum value of *G* encountered during impact.

The test set-up was positioned over the sub base with the clearview bumper II (gmax test equipment) placed level over the entire system. The missile was released, so as to impact the center of the assembly at a velocity of 3.43 m/s at a drop height of 24". Three drops were made at 3 minute intervals. This procedure was repeated in three different locations for a total of nine drops. The first drop at each location was for assembly conditioning and was not included in the average.

Test Data: Turf + Infill System Over Sub Base			
Location	G-Max Read Drop #2	G-Max Reading Drop #3	Average G-Max Reading
1	102	105	104
2	110	112	111
3	110	112	111
OVERALL GMAX:			109

Test Data: Turf + Infill System + 4 oz Filter Fabric + AirDrain + 10 oz Filter Fabric Over Sub Base ↓			
Location	G-Max Read Drop #2	G-Max Reading Drop #3	Average G-Max Reading
1	90	93	92
2	91	95	93
3	92	96	94
OVERALL GMAX:			93

Conclusion: Use of the filter fabrics and AirDrain with infilled synthetic turf reduced Gmax attenuation 14.7 % verses Gmax attenuation which employed just the turf + infill system using the same sub base.

PROPER SEQUENCING ORIENTATION OF AIRPAVE GEOCELL PANELS FOR RAPID INSTALLATION

Pallet Staging: AirPave pallets cover approximately 798sqft. per pallet and should be staged accordingly within the installation area to minimize the amount of time to stage the AirPave grid. AirPave pallets are typically placed every 65 feet across and 15-20 feet back from each other. (Call AirField with questions that you might have about proper staging and installation.)

All Installations must start in the Top Left Corner of the project and work Left to Right to be installed properly.

1. Orientate the AirPave GeoCell materials with the integral indicator tab to the panel's bottom left corner (painted yellow). Install the AirPave units by placing units with connectors and the pinning platforms flush against the prepared subbase. If the female connectors do not go over the male connectors then the orientation is incorrect, please call AirField Systems Immediately at 405-359-3775.
2. Install the AirPave panels across the field in a rowed pattern. Staggering of rows will allow for multiple row completion by a multi-manned crew.

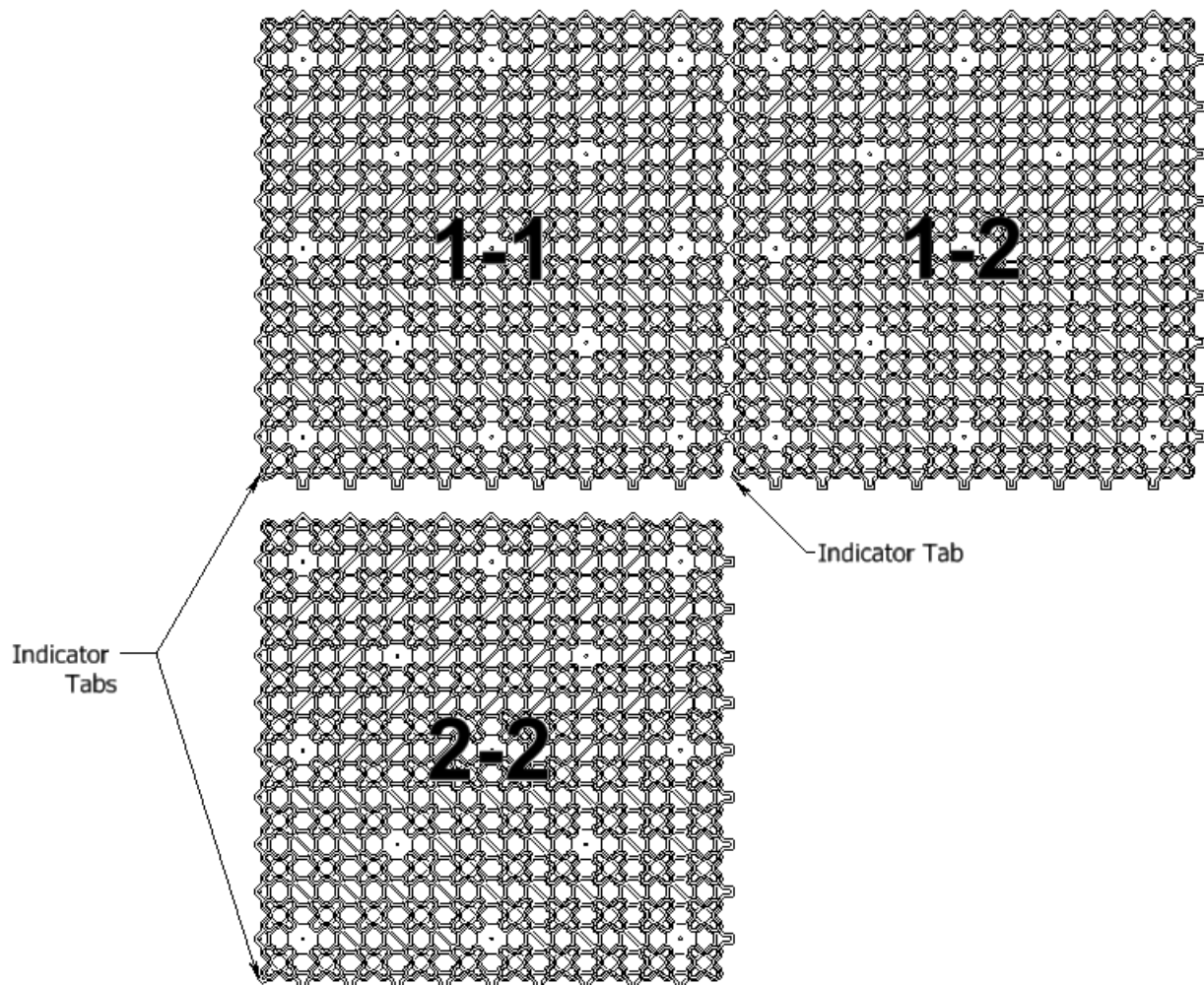

3. Secure the first panel to the base with pins (Only in AirPave paved grass installations) and commence with panels 1-2, 1-3, and so on with one directional pull to secure. (Optional)
4. Once the first row has progressed across the project, start with a second row. Have a person staging the panels in groups of three snapped together along the row. The crew can then install the left side of the panel while elevating slightly the top portion (so the male and female connectors don't touch each other) once the left side has been snapped with a pull along the row direction, the top portion should fall into place and with a bottom vertical pull holding the inside of parts 1 & 3 snap all three parts in place.



5. AirPave panels can be shaped to individual field areas as needed with appropriate cutting device.
 - A. If only a few parts need to be trimmed, use tin snips.
 - B. If many parts require trimming, set up a table and use a circular saw with a no melt, plastic cutting saw blade.
6. AirPave units placed on curves and slopes shall be anchored to the base course, using 8 inch (203 mm) Chisel Point Pins 6 gauge BB Wire and 1 1/2 (35 mm) round attached washers, as required to secure units in place.

DISCLAIMER: The preceding and following drawings and/or general installation guidelines are provided only to show a concept design for installation and are not instructions for any particular installation. These drawings and general instructions are not complete and are provided only to assist a licensed Geo-Technical Engineer, a Landscape Architect and/or Civil Engineer in preparing actual construction and installation plans. These drawings and instructions must be reviewed by a licensed Geo-Technical Engineer, a Landscape Architect and/or Civil Engineer and adapted to the condition of a particular installation site and to comply with all state and local requirements for each installation site. **THESE DRAWINGS AND/OR GENERAL INSTRUCTIONS DO NOT MODIFY OR SUPPLEMENT ANY EXPRESS OR IMPLIED WARRANTIES INCLUDING MERCHANTABILITY AND FITNESS FOR A PARTICULAR PURPOSE, IF APPLICABLE RELATING TO THE PRODUCT.**

100% POST MANUFACTURED CONTENT

The AirPave GeoGrid is made of 100% post-manufactured material, you can feel good about helping the planet while adding valuable LEED Points to your project! We also add an impact modifier for incredible strength and superior performance in extreme heat and cold - on top of the already durable AirPave design.

AirPave Co-Polymer with an Impact Modifier Performance and Temperature durability

Attached you will find the specifications of the resin used to product both the 32 x 32 and the 32 x 18 Geocells. This material is a co-polymer polypropylene that is 100% recycled resin. In order to be able to produce a consistent recycled resin a PIR (post industrial resin) is used for the base resin. This is the only way to product a consistent material as opposed to a PCR (post consumer resin) which is dependent on the consumer to supply a consistent material. Using the PIR as a base resin, 3% carbon black is added to insure good UV stabilization and metallocene (an ethylene base material) is used as an impact modifier.

Impact Modifier

The impact modifier is added in an amount that achieves a 10.0 notched izod impact which comfortably qualifies this material as a NO BREAK material (4.0 and greater are normally considered no break material). The AirPave resin offers an advantage over many ethylene and HDPE products since the AirPave resin is often superior when it comes to pliability, warping and internal stress related issues. Refering to the attached specification sheet you will notice that all testing is done to specific ASTM standards.

Resin Blends

AirPave's blend of resins gives it the ability to perform in extreme temperatures. AirPave does not need a temperature above 40 degrees Fahrenheit to be installed or warmed in the sun to be pliable on site for install. In addition, AirPave's unique resin blend also helps prevent breakage and cracking in extreme temperatures, thus giving it the ability to withstand repeated freeze thaw cycles.

PROUDLY MADE IN THE USA



AIRFIELD SYSTEMS

THE PROVEN ARTIFICIAL TURF DRAINAGE SOLUTION



WWW.AIRFIELDSYSTEMS.COM